

EIA-485 / RS-232

Communications Adapter

Installation and Operation Manual

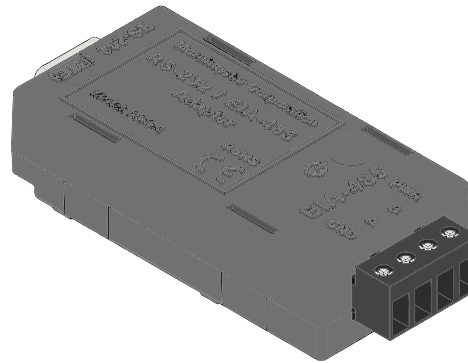

Model: RSC-1



1098 Washington Crossing Road
Washington Crossing, PA 18977 USA
www.morningstarcorp.com

Dimensions

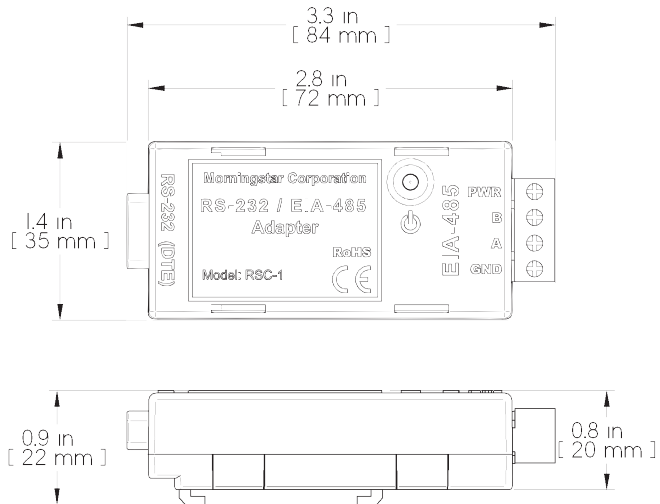

Figure 1. RSC-1 Dimensions.

Technical Specifications

Power Input Voltage	8V - 16V
Self Consumption	8 - 16 mA
Baud Rate	9600 baud
EIA-485 Network Unit Load	1/4
Operating Temperature	-40 C to +60 C
Storage Temperature	-55 C to + 80 C
Humidity	100% N.C.
Enclosure	IP20
Dimensions	72 x 35 x 23 mm
Weight	37 g (1.3 oz)
DIN Rail Compatibility	35 mm (1-3/8")
Certifications	CE, RoHS
Warranty	2 years

Features

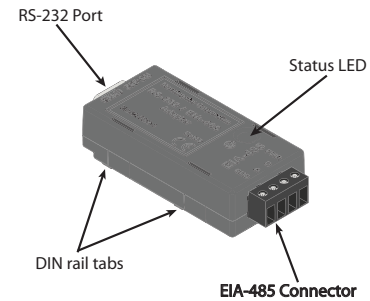

Figure 2. RSC-1 features.

- Removable four (4) position EIA-485 terminal
- 9-pin RS-232 connector (male)
- Status LED for monitoring and diagnostics
- Molded tabs for attachment to 35 mm standard DIN rail
- RS-232 ribbon cable (not shown) with low-profile connectors

Mounting

The RSC-1 can be mounted on standard 35 mm DIN rail. Four (4) tabs are molded into the bottom of the case. Slide the RSC-1 onto an open end of the DIN rail.

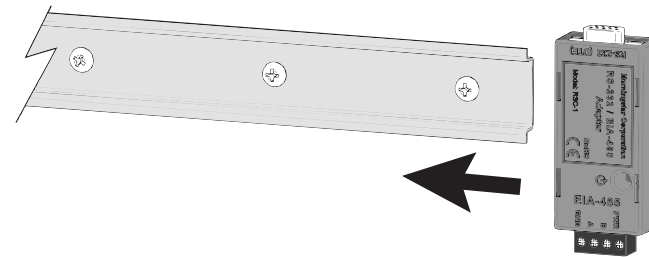

Figure 3. Mounting the RSC-1 to DIN rail
Morningstar Corporation

Wiring

Step 1 Daisy-chain EIA-485 Connections

RSC-1 adapters are daisy-chained together as shown in figure 4. Twisted pair communication cable is highly recommended to maintain data integrity.

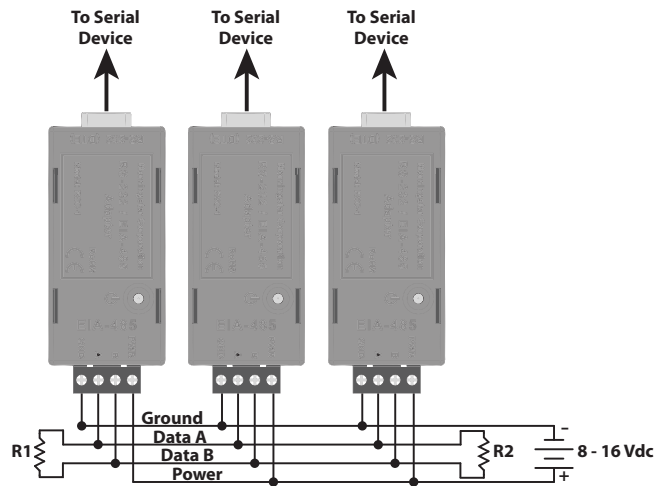

Figure 4. EIA-485 bus wiring

Step 2 - Termination Resistors

Termination resistors (R1 & R2) must be placed on both ends of the data bus as shown in figure 4. If the characteristic impedance of the communication cable is Z_0 , then:

$$R1 = R2 = Z_0$$

Check the communication cable specifications for the characteristic impedance.

The typical characteristic impedance of select cables are shown in table 1 below.

Cable Type	Characteristic Impedance
RS-485 single twisted pair	120 ohm
Category 5 Ethernet	100 ohm

Table 1. Characteristic impedances.

Step 3 - Serial RS-232 Connections

Connect a Morningstar controller, inverter, or accessory to the RS-232 port on the RSC-1 using a straight-through serial cable. A low-profile serial ribbon cable is included with the RSC-1.

Use a *Null Modem* serial crossover cable to connect a PC (or other DCE serial device) to the RSC-1. A Null Modem cable is not included.

Step 4 - EIA-485 Bus Power

The EIA-485 network requires external power. The source voltage must be between 8-16 Vdc. For 12 Volt systems, the network can be powered directly from the system battery. Use a DC-DC converter for 24, 36, and 48 Volt systems.



Caution: Tapping power off of individual batteries in a battery bank can cause a voltage imbalance. Damage to the batteries may result. Always use a DC-DC converter if the nominal system voltage is greater than 12 volts.

Morningstar Corporation

Network Rules

- Each Morningstar controller, inverter, and accessory on the network must be programmed with a unique Modbus Address. Addresses can be programmed using Morningstar's MSView PC software.
- Do not wire more than 128 RSC-1 adapters on a single EIA-485 network (RSC-1 is 1/4 Unit Load)
- Use twisted pair communication cable for the EIA-485 bus.
- Do not run network cables in the same conduit or trough as the system power cables or AC wiring. In general, avoid running network cables in parallel with power cables.
- A MeterBus to Serial Converter (model: MSC) can be used to communicate with Morningstar products that do not have a serial port. See MSC documentation for supported products.

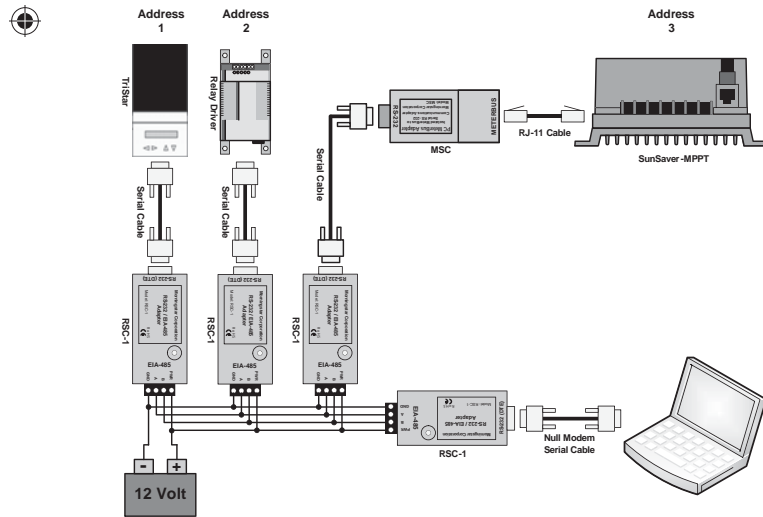

Figure 5. An example EIA-485 network (termination resistors not shown)

Status LED Indications

The Status LED indicates adapter power and network communication. Table 2 below identifies each of the indication types.

Status LED	Indication	Note
Off	No bus power or reverse polarity	Check EIA-485 bus power & polarity
Green	Power OK, no data on network	Wiring OK, Ready for transmit / receive
Green / Red Flicker	Data on network	Network OK
Orange	Reversed A & B data lines	Check network wiring

Table 2. LED Indications

Inspection and Maintenance

The following inspections and maintenance tasks are recommended at least two times per year for best performance.

- ✓ Tighten all terminals. Inspect for loose, broken, or corroded connections.
- ✓ Verify that all wire clamps and tie-downs are secure.
- ✓ Check that the adapter is mounted in a clean, protected environment; free of dirt, insects, nests, and corrosion.
- ✓ Verify LED indication is consistent with the present system conditions.

Morningstar Corporation

Warranty

The EIA-485/RS-232 Communications Adapter (RSC-1) is warranted to be free from defects in material and workmanship for a period of TWO (2) years from the date of shipment to the original end user. Morningstar will, at its option, repair or replace any such defective products.

CLAIM PROCEDURE

Before requesting warranty service, check the Operator's Manual to be certain that there is a problem with the RSC-1. Return the defective product to your authorized Morningstar distributor with shipping charges prepaid. Provide proof of date and place of purchase.

To obtain service under this warranty, the returned products must include the model, serial number and detailed reason for the failure. This information is critical to a rapid disposition of your warranty claim.

Morningstar will pay the return shipping charges if the repairs are covered by the warranty.

WARRANTY EXCLUSIONS AND LIMITATIONS

This warranty does not apply under the following conditions:

- Damage by accident, negligence, abuse or improper use.
- Voltage or currents exceeding the ratings of the product.
- Unauthorized product modification or attempted repair.
- Damage occurring during shipment.

THE WARRANTY AND REMEDIES SET FORTH ABOVE ARE EXCLUSIVE AND IN LIEU OF ALL OTHERS, EXPRESS OR IMPLIED. MORNINGSTAR SPECIFICALLY DISCLAIMS ANY AND ALL IMPLIED WARRANTIES, INCLUDING, WITHOUT LIMITATION, WARRANTIES OF MERCHANTABILITY AND FITNESS FOR A PARTICULAR PURPOSE. No Morningstar distributor, agent or employee is authorized to make any modification or extension to this warranty.

MORNINGSTAR IS NOT RESPONSIBLE FOR INCIDENTAL OR CONSEQUENTIAL DAMAGES OF ANY KIND, INCLUDING BUT NOT LIMITED TO LOST PROFITS, DOWNTIME, GOODWILL OR DAMAGE TO EQUIPMENT OR PROPERTY.

1098 Washington Crossing Road,
Washington Crossing, PA 19877 USA
Email: info@morningstarcorp.com
Website: www.morningstarcorp.com

RoHS
CE

Morningstar Corporation

MS-ZMAN-RSC-01